

FREESTANDING WALL ADD ON 4FT :: 257-W-DSFS-4-AO

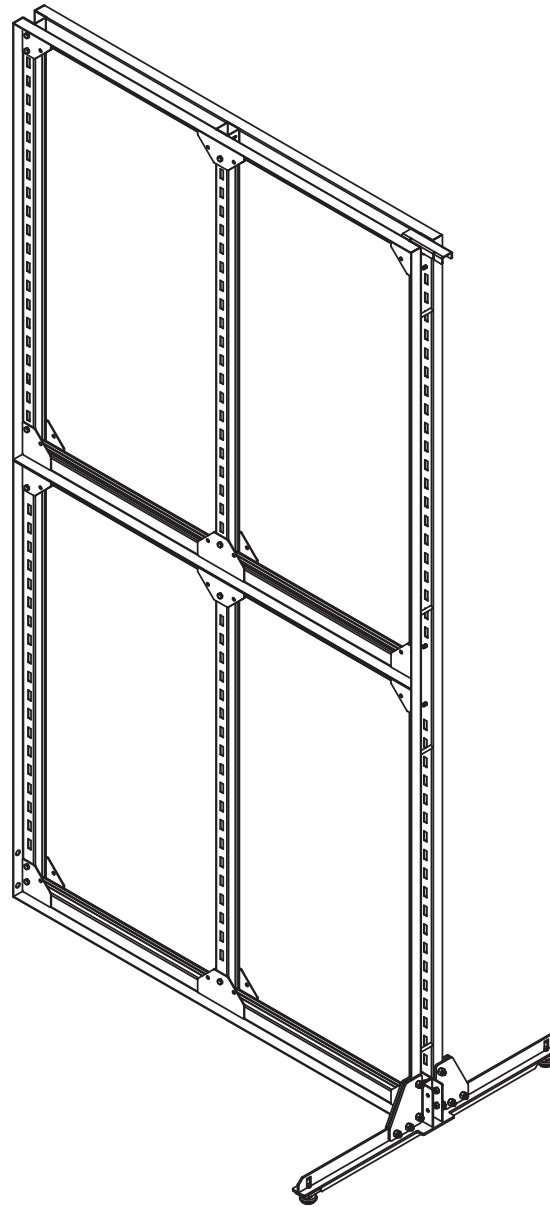

ASTORIA
ASSEMBLY INSTRUCTIONS



PART LIST:



1X. LEFT UPRIGHT



1X. RIGHT UPRIGHT



1X. CENTER UPRIGHT

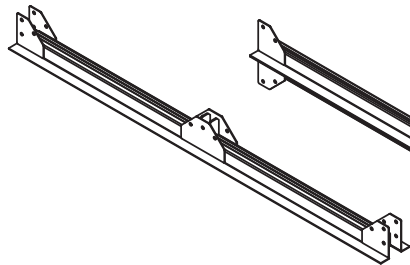

1X. BOTTOM RAIL

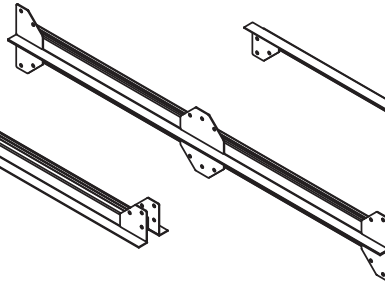

2X. CENTER RAIL

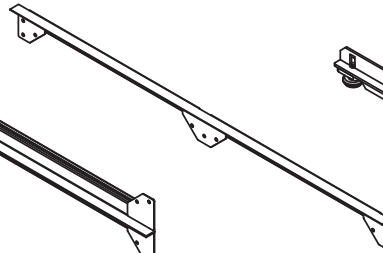

2X. TOP RAIL

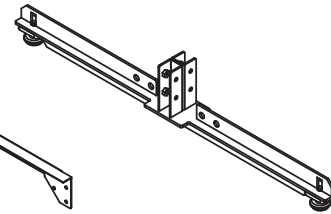

1X. CENTER LEG FREESTANDING WALL

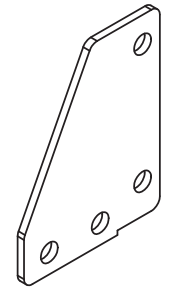

4X. LEG BRACKET

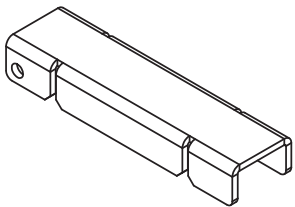

1X. BRACKET

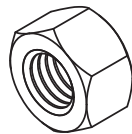

8X. HEX NUTS 3/8-16

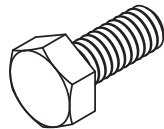

32X. HEX BOLT 1/4"-20 X 0.625"

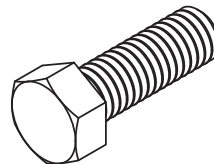

8X. HEX BOLT 3/8"-16 X 1.125"

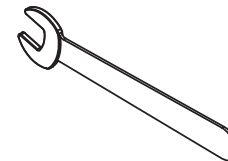

1X. OPEN END WRENCH FOR HEX BOLT 1/4-20 UNC

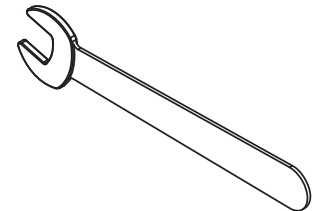

1X. OPEN END WRENCH FOR HEX BOLT 3/8"-16 UNC

STEP 1: ASSEMBLE CENTER UPRIGHTS

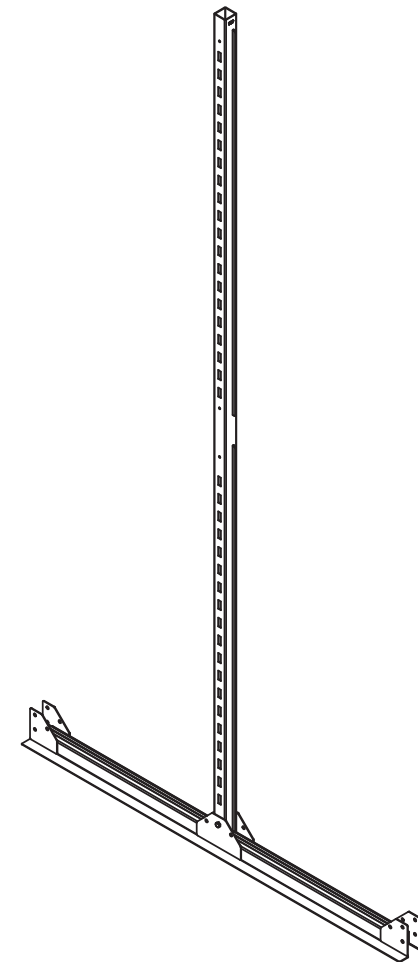
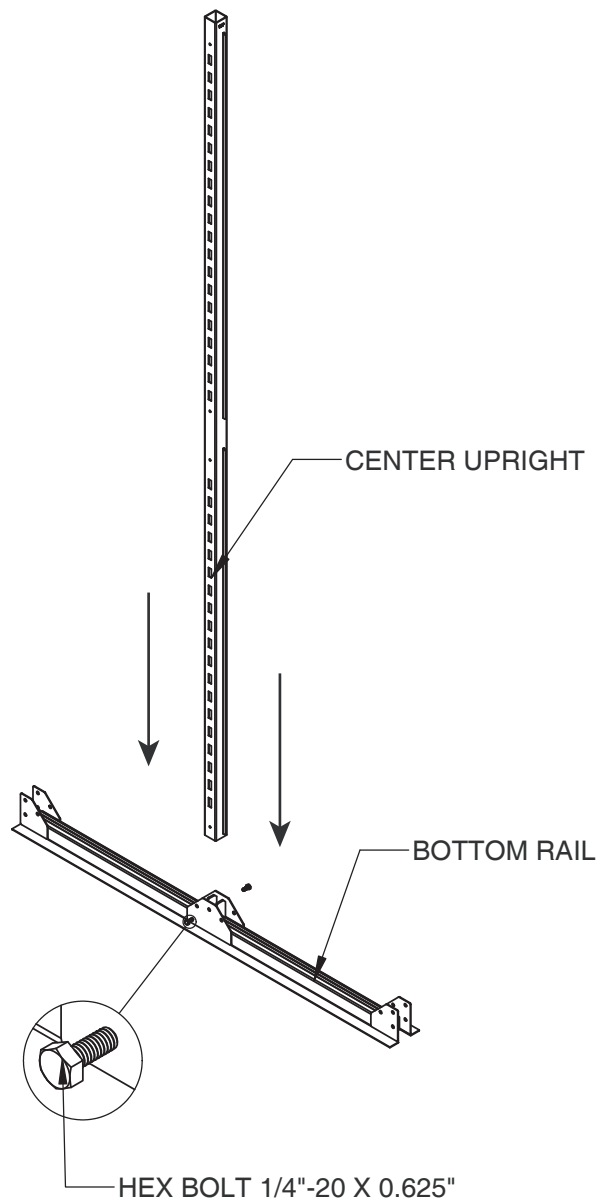

STEP 2: CONNECT LEGS TO UPRIGHTS

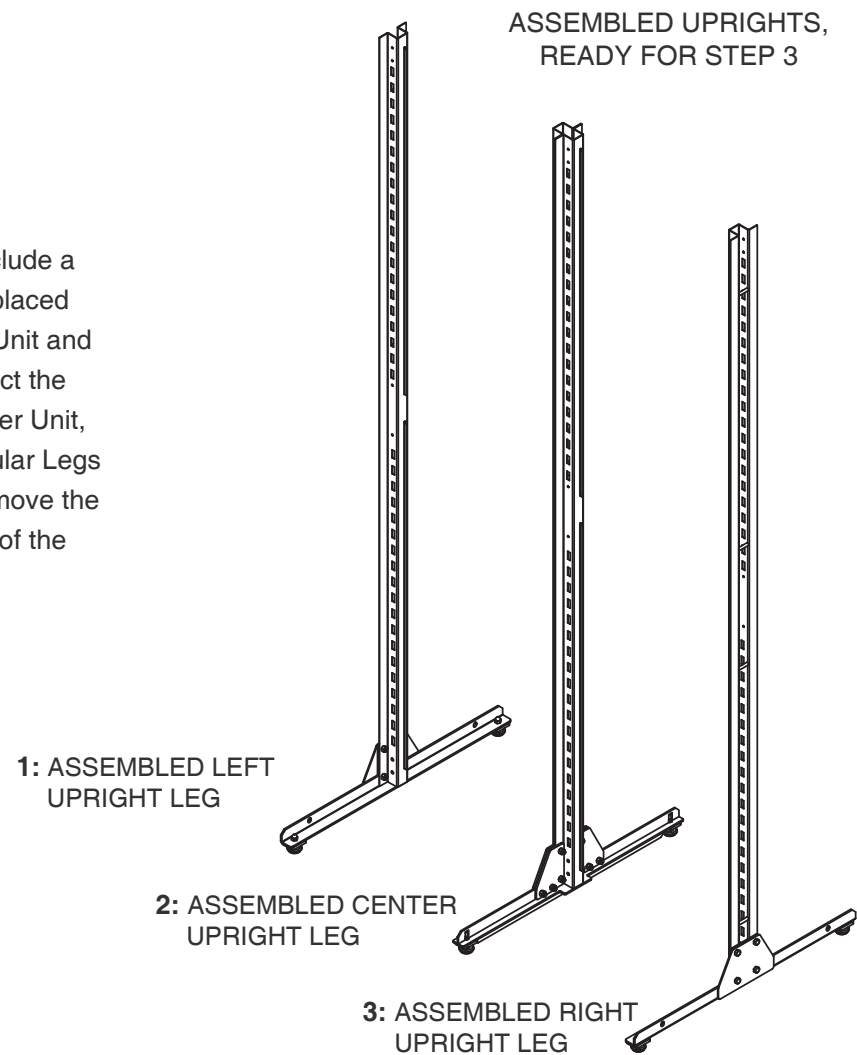
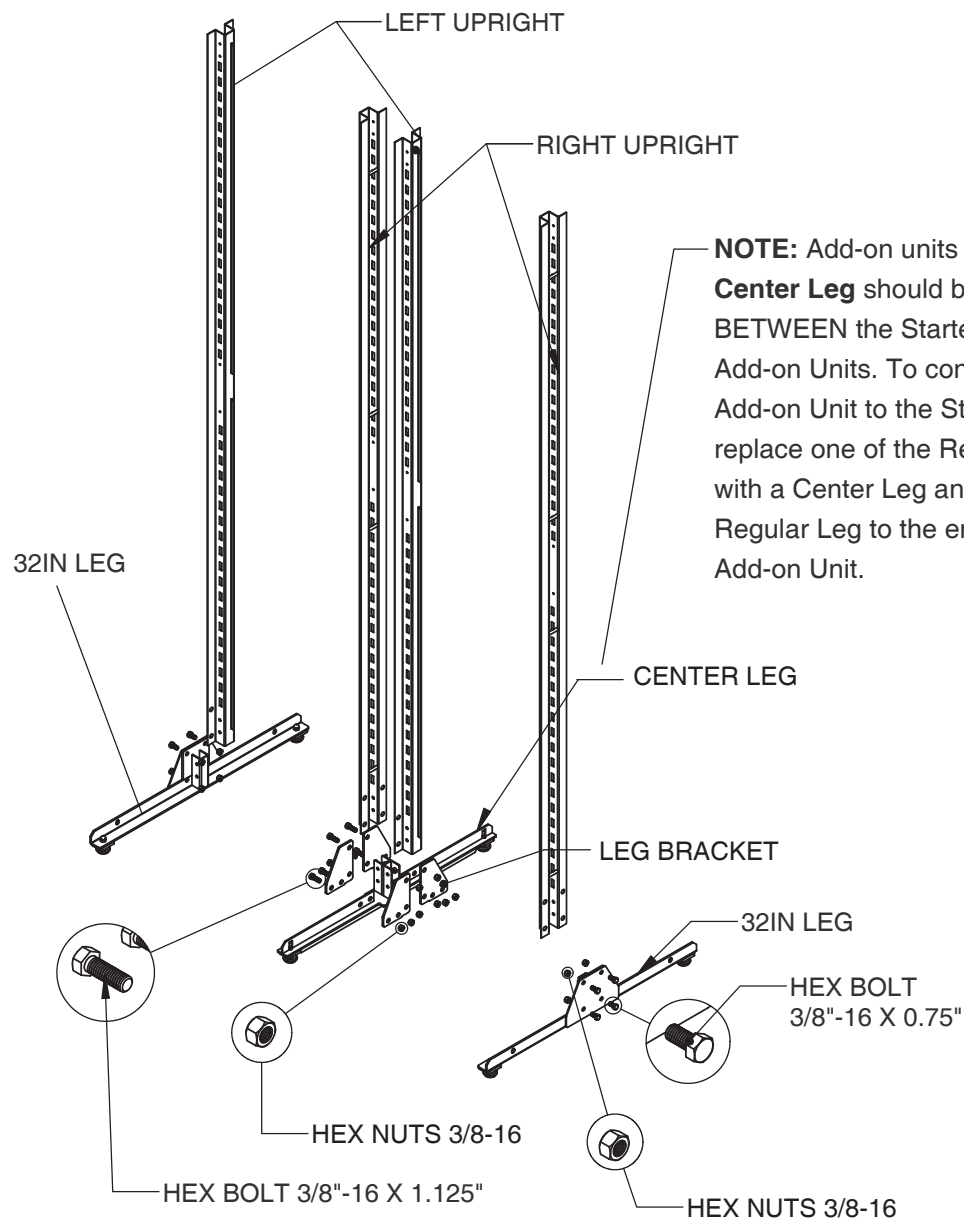

STEP 3: CONNECT TOP & CENTER RAILS TO THE TWO CENTER UPRIGHTS

Connect the Top Rails and Center Rails to Center Uprights
using HEX BOLT 1/4"-20 X 0.625"

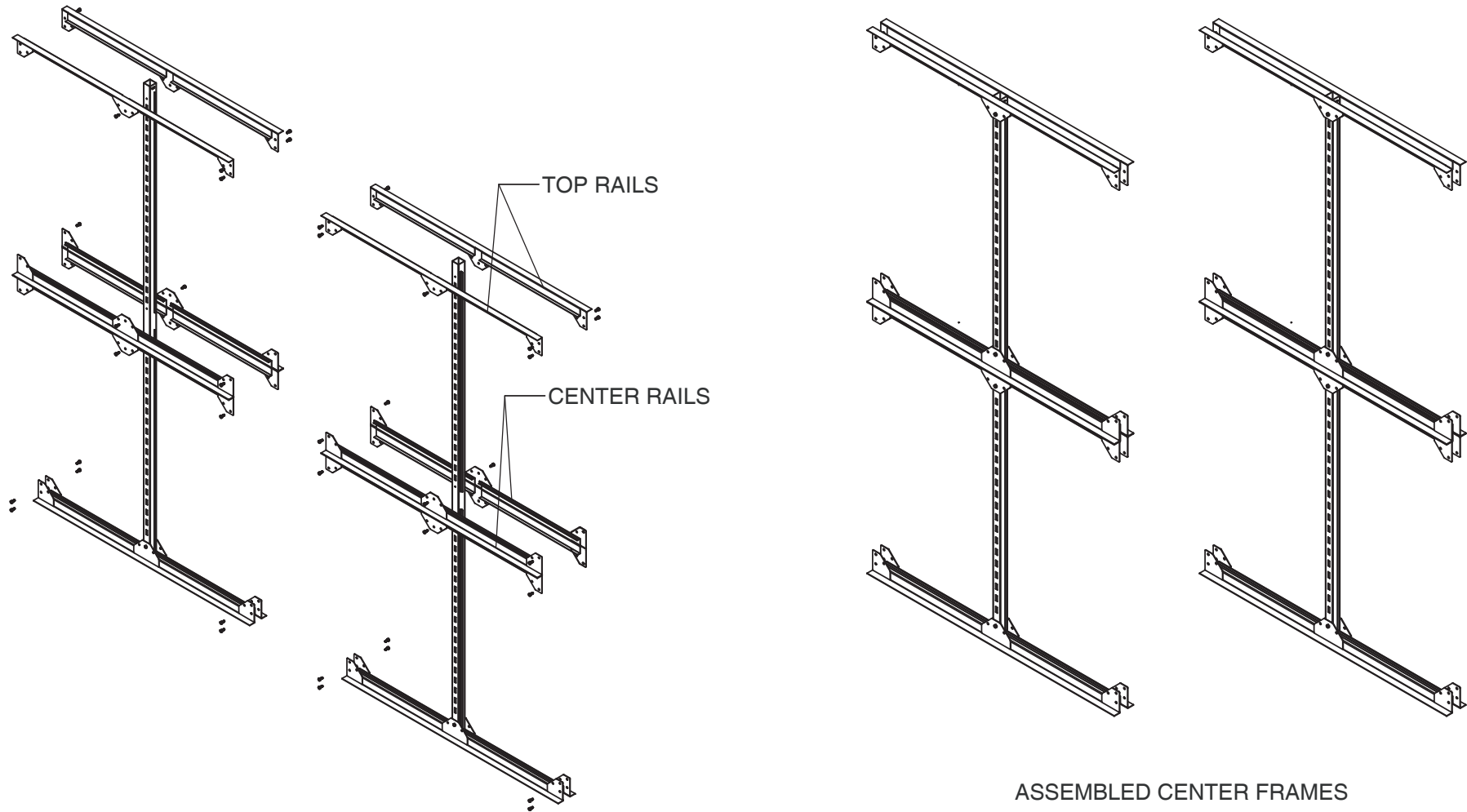

STEP 4: CONNECT CENTER UPRIGHTS TO LEFT & RIGHT UPRIGHTS

STEP 4A: Connect Legs to Center & Top Rails using
HEX BOLT 1/4"-20 X 0.625"

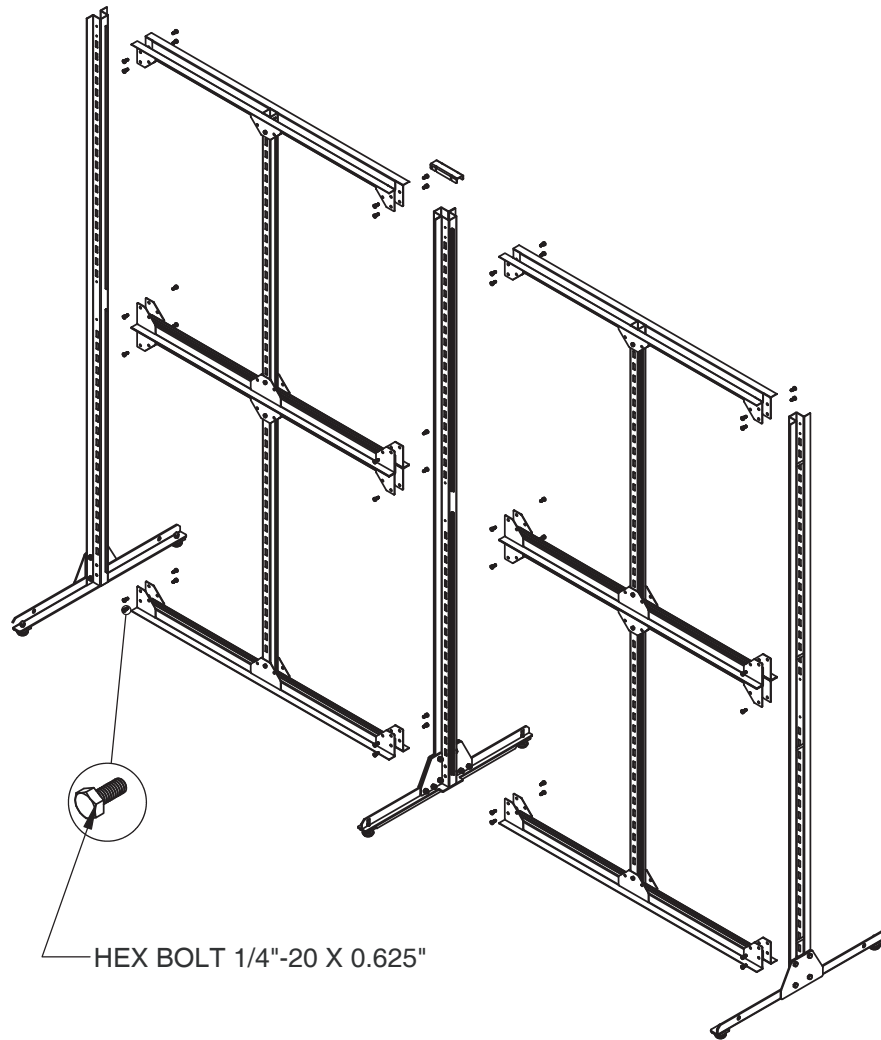

STEP 4B: Connect completed
Wall Add-on to Wall Starter
unit using Bracket

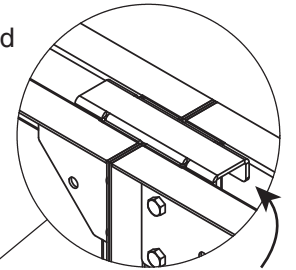

BRACKET CONNECTS
MULTIPLE FRAMES

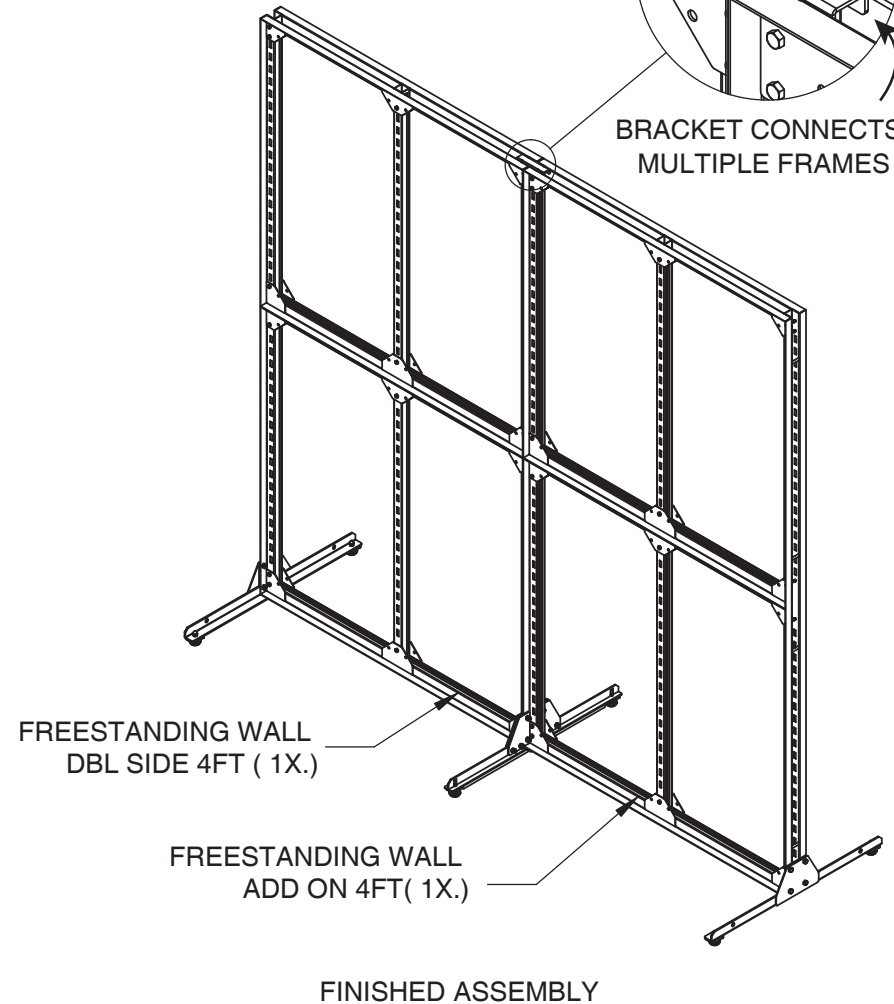

STEP 4: W/ OPTIONAL CROSS BRACES

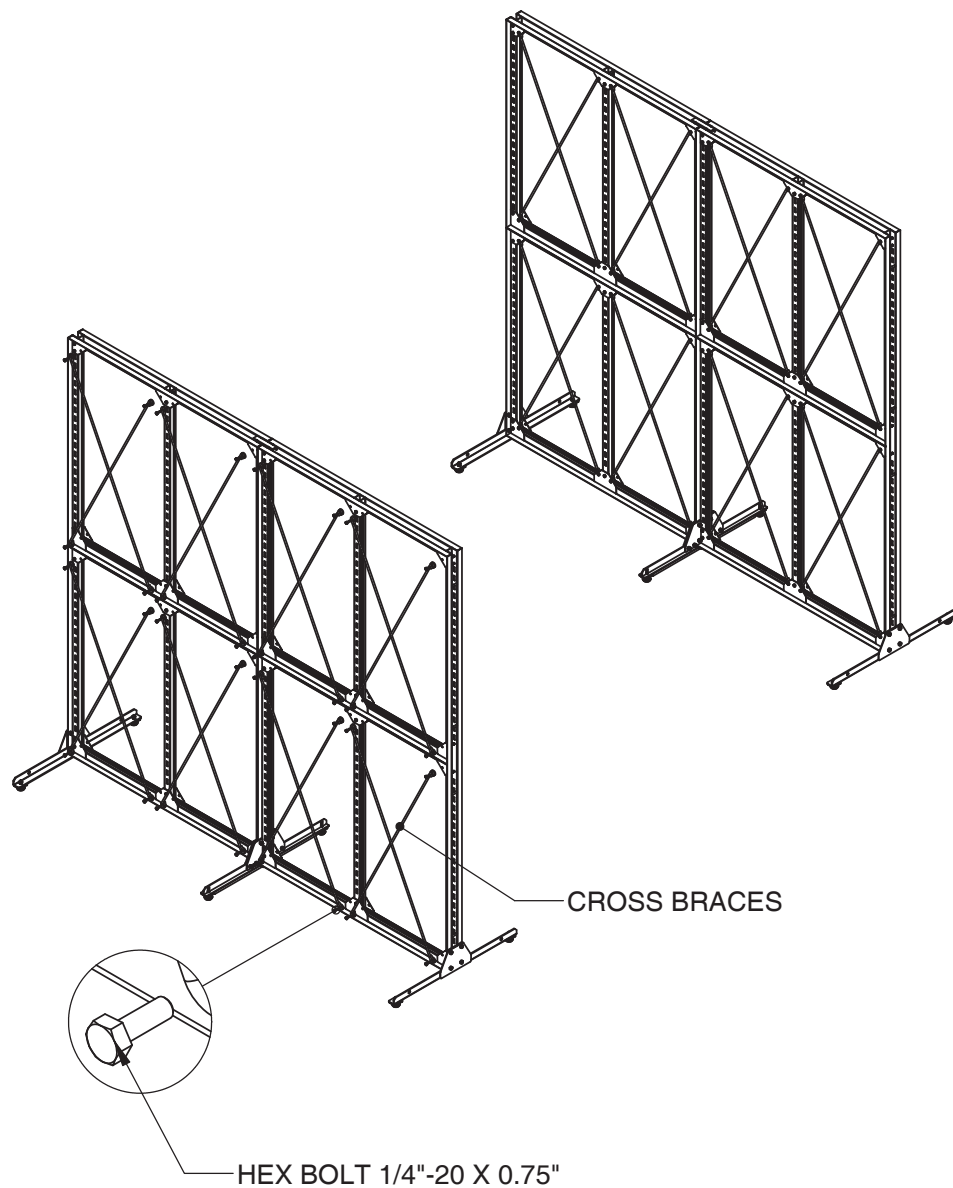

STEP 3: W/ OPTIONAL BACK PANELS

